

**Centac® 2 CV1-1**

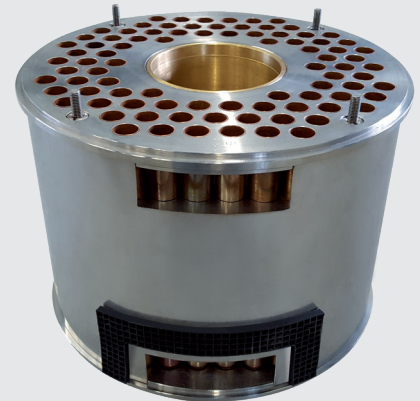

**Centac® C 250-3**



**Centac® 1 Frame 1**

## AIR COOLING - EFFICIENT & ECONOMIC

The air coolers in Centac® compressors have a huge influence on their efficiency and thus also on their operating costs. In order to run a compressor economically over the long term, it is therefore extremely important that users of the compressors deploy high quality and technically advanced air coolers.

VTS International GmbH has precisely fulfilled this customer requirement by developing and producing the best quality air coolers currently available on the market. Our advanced manufacturing technology and the use of a balanced quantity

of tubes, in which the compressed air is cooled, enable our air coolers, which are following the OEM design, to offer a perfect balance between pressure loss and CTD values.

An ISO 9001:2015 certification and the fact that we are keeping our production in Germany witness our focus on a product, meeting the highest quality standards. We furthermore continuously invest to decrease delivery times and therefore operate a stock with more than 100 air coolers for various Centac® models, being ready for immediate delivery to the customer.

**WWW.VTSGMBH.DE**



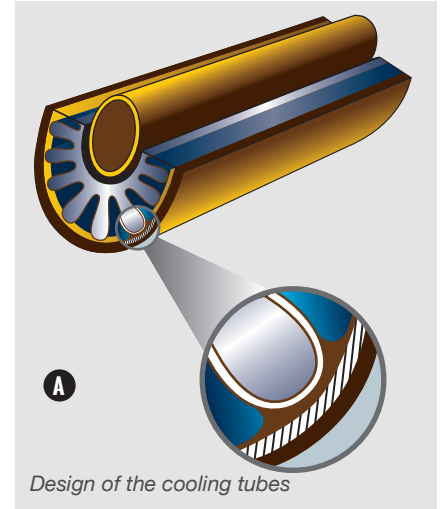
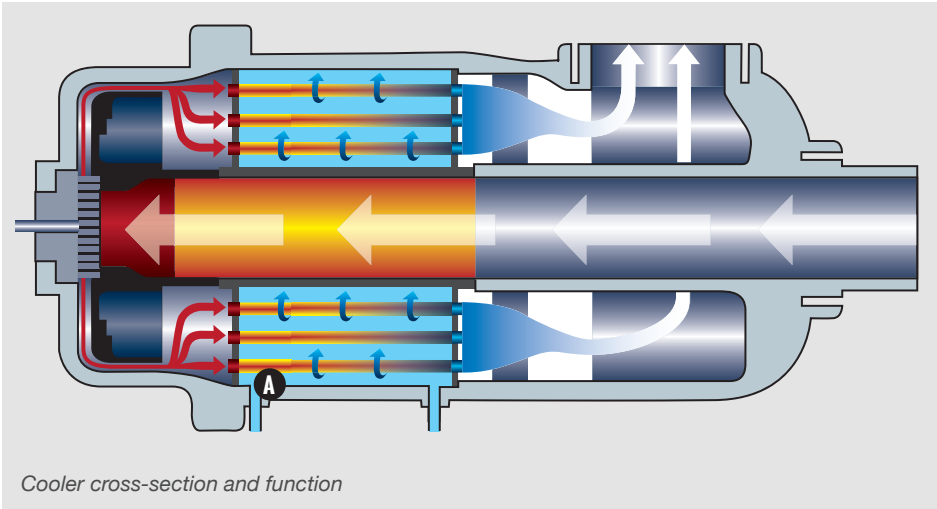

## DELIVERY RANGE

Cooler seals and waffle gaskets for our entire delivery range can likewise be supplied as and when needed.

Centac <sup>®</sup> 1	Tube sheets	Tubes		Coating
		Standard	Option	
Frame 1	Stainless steel	Copper	Copper-nickel	Available
Frame 2	Stainless steel	Copper	Copper-nickel	Available
Frame 3	Stainless steel	Copper	Copper-nickel	Available
Frame 4 - 110	Stainless steel	Copper	Copper-nickel	Available
Frame 4 - 150	Stainless steel	Copper	Copper-nickel	Available

Centac <sup>®</sup> 2	Tube sheets	Tubes		Coating
		Standard	Option	
CV1	Stainless steel	Copper	Copper-nickel	Available
CV1A	Stainless steel	Copper	Copper-nickel	Available
CV2	Stainless steel	Copper	Copper-nickel	Available
2ACII	Stainless steel	Copper	Copper-nickel	Available
2CII	Stainless steel	Copper	Copper-nickel	Available
3CII	Stainless steel	Copper	Copper-nickel	Available
5CII	Stainless steel	Copper	Copper-nickel	Available

Centac <sup>®</sup> C	Tube sheets	Tubes		Coating
		Standard	Option	
CH4	Stainless steel	Copper	Copper-nickel	Available
CH5	Stainless steel	Copper	Copper-nickel	Available
CH6	Stainless steel	Copper	Copper-nickel	Available
C250	Stainless steel	Copper	Copper-nickel	Available
C350	Stainless steel	Copper	Copper-nickel	Available
C700	Stainless steel	Copper	Copper-nickel	Available
C800	Stainless steel	Copper	Copper-nickel	Available
C950	Stainless steel	Copper	Copper-nickel	Available
C1000	Stainless steel	Copper	Copper-nickel	Available
C3000	Stainless steel	Copper	Copper-nickel	Available